

Dialogannahme

ADAS CALIBRATION

Version 2026.05.12 – Prices on request

VAS 6430/1A | Calibration Fixture Base Frame

Article number: ASE 423 211 01 000

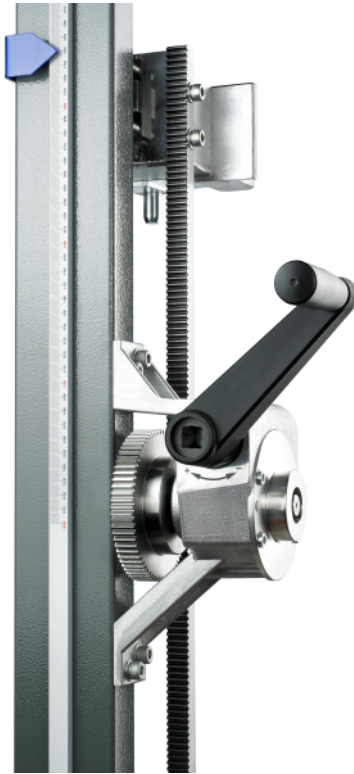

Il VAS 6430/1A costituisce il basamento dell'attrezzatura di calibrazione VAS 6430. Tutti gli adattatori per la calibrazione dei sistemi di assistenza alla guida rivolti in avanti per il Gruppo VW vengono montati sul basamento VAS 6430/1A. Two options are available for installing the calibration fixture in the workshop:

- The VAS 6430/8 mobile base frame for flexible positioning.
- The VAS 6430/7 stationary base frame with an XY rail system.

If front camera calibrations are performed on an above-ground lift, the VAS 6430/9 adapter must also be used. This serves as height compensation, as the front camera is installed very high on some transporters and light commercial vehicles (LCVs).

Older VAS 6041 (for ADR) and VAS 6190 (for ACC) calibration fixtures can be retrofitted using this base frame.

Important: Procurement is carried out exclusively through authorized Volkswagen Group distribution channels.

VAS 6430/4 | Calibration Target Front Camera

Article number: ASE 423 214 00 000

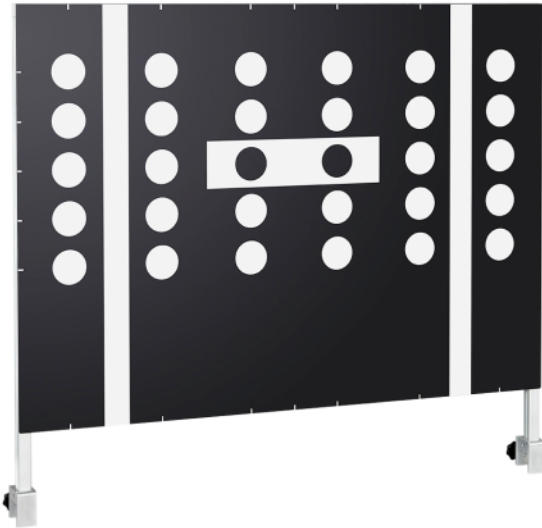

The VAS 6430/4 calibration board is used to calibrate the front camera, which is required for functions such as the automatic Lane Keep Assist. The Lane Keep Assist warns the driver by vibrating the steering wheel if they unintentionally leave the lane. The VAS 6430/4 calibration board is mounted on the VAS 6430/1A base frame and aligned with the vehicle. The actual software calibration is performed using the diagnostic tester. Advantage when used in conjunction with the VAS 701011 wheel aligner: No measuring tapes are required for correct positioning. The alignment is fully digital, including automatic compensation for height differences between the calibration fixture and the vehicle's contact surface. Important: Procurement is carried out exclusively through authorized Volkswagen Group distribution channels.

VAS 6430/12 | Calibration Target LiDAR

Article number: ASE 423 222 00 000

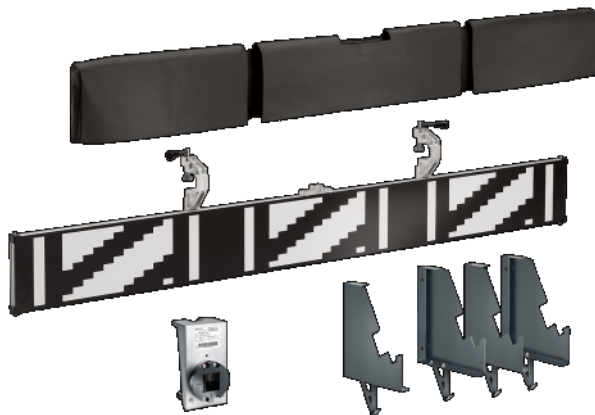

The VAS 6430/12 calibration board is used for the calibration of LiDAR sensors and is attached to the VAS 6430/1A base frame. LiDAR sensors were first installed in the Audi A8 (2018) and are increasingly required to support autonomous driving functions. For calibration, the VAS 6430/12 is mounted on the crossbar of the VAS 6430/1A base frame, including the VAS 6430/12-2 laser mount. The VAS 6350/3A laser is inserted into this mount to perform the positioning relative to the LiDAR sensor. The actual software calibration is performed via the diagnostic tester. Since the other calibration adapters must be stowed away while using the VAS 6430/12, two wall brackets are included in the scope of delivery. These can be used to store either both radar calibration adapters (VAS 6430/3 and VAS 6430/10) or the VAS 6430/12.

Important: Procurement is carried out exclusively through authorized Volkswagen Group distribution channels.

VAS 6430/11 | Calibration Target LDW

Article number: ASE 423 221 00 000

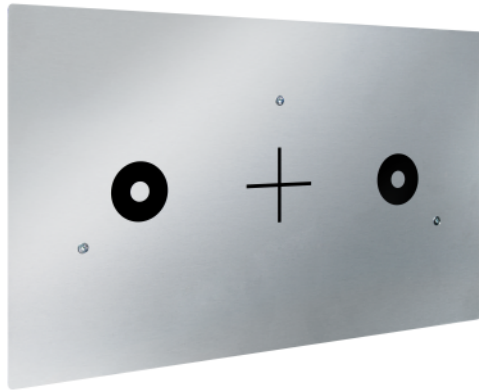

The VAS 6430/11 calibration board is used for calibrating the front camera and is attached to the VAS 6430/1A base frame. This calibration board is required exclusively for the VW Crafter (Type 2E) 2012-2016 and is mounted over the universal VAS 6430/4 front camera calibration board. Important: Procurement is carried out exclusively through authorized Volkswagen Group distribution channels.

VAS 6430/9 | Height Spacer

Article number: ASE 423 219 00 000



The VAS 6430/9 adapter is used for height compensation on above-ground lifts and is mounted between the base frame and the VAS 6430/1A base frame for this purpose. This makes it possible to calibrate the front cameras—which are installed very high on some transporter and LCV models—even at these measurement bays. The height compensation adapter is compatible with both the VAS 6430/7 stationary base frame and the VAS 6430/8 mobile base frame.

VAS 6430/6 | Calibration Adapter Night Vision

Article number: ASE 423 216 01 000



The VAS 6430/6 calibration adapter is used to calibrate the Night Vision Assistant and is mounted on the crossbar of the VAS 6430/1A base frame. The VAS 6430/6 is positioned in the center of the direction of travel using a wheel aligner and serves as a reference heat source for the thermal imaging camera, which can be recalibrated under the guidance of a diagnostic device. Note: Power supply unit included in the scope of delivery; power cable not included. A country-specific power cable with a C13 coupler (IEC C13) is required to connect to the power supply unit. Important: Procurement is carried out exclusively through authorized Volkswagen Group distribution channels.

VAS 6430/2 | ACC Laser Unit

Article number: ASE 423 212 00 000

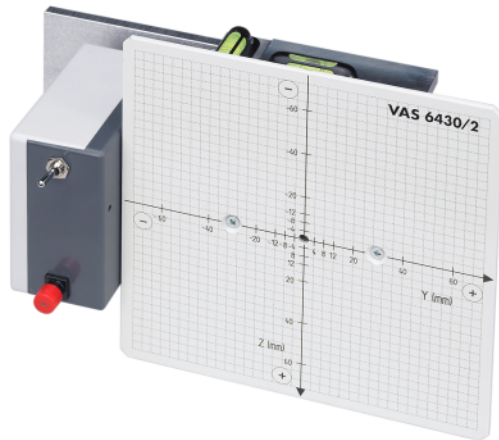

The VAS 6430/2 ACC laser unit is used for the mechanical pre-alignment of ACC sensors on VW vehicles and is attached to the crossbar of the VAS 6430/1A base frame. The VAS 6430/2 laser unit is used for the mechanical pre-alignment of ACC sensors on VW vehicles (e.g., after a sensor replacement). The process takes place in two steps:

- First, the laser unit is precisely aligned with the radar sensor.
- Based on the reflected laser point on a 150x150 mm measuring scale, the sensor is mechanically adjusted into the correct position.

The actual software calibration via the diagnostic tester can only be carried out after this correct pre-alignment has been completed. Note: A pre-alignment mirror, which is attached to the radar sensor, is required to reflect the laser point. This is only included in the scope of delivery for the VAS 6430/3! Batteries are not included in the scope of delivery. 4 x 1.5V AA batteries are required. Important: Procurement is carried out exclusively through authorized Volkswagen Group distribution channels.

VAS 6430/10 | ACC Reflective Mirror

Article number: ASE 423 220 00 000



The ACC Reflective Mirror VAS 6430/10 is used for the calibration of the radar sensor and is attached to the crossbar of the VAS 6430/1A base frame. Using an integrated laser, the 750x600 mm mirror can be aligned with the radar sensor. The actual software calibration is performed using the diagnostic tester. Note: Batteries are not included in the scope of delivery. 4 x 1.5V AA batteries are required. Important: Procurement is carried out exclusively through authorized Volkswagen Group distribution channels.

VAS 6430/8 | Moveable Base Frame

Article number: ASE 423 218 00 000



The mobile base frame is required as an accessory to hold the VAS 6430/1A base frame. The base frame can be moved transversely to the vehicle via four synchronized wheels. It can also be moved in the longitudinal direction to the vehicle using a drawbar. It is re-leveled after each movement using the 3 leveling feet. Important: Procurement is carried out exclusively through authorized Volkswagen Group distribution channels.

VAS 6430/7 | Stationary Base Frame

Article number: ASE 423 217 00 000

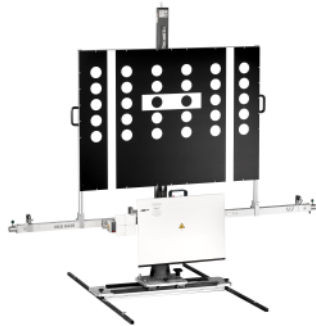

The base frame, designed as an XY slider with precision rails, is used to hold the VAS 6430/1A base frame. The rails are leveled and secured to the floor. This allows various distances to be set significantly faster and eliminates the need for subsequent leveling readjustments. Depending on the vehicle's driver assistance system equipment, a time saving of at least 10 minutes is possible. Important: Procurement is carried out exclusively through authorized Volkswagen Group distribution channels.

VAS 6430/3 | ACC Reflective Mirror

Article number: ASE 423 213 00 000



The ACC Reflective Mirror VAS 6430/3 is used for the adjustment of ACC sensors on Audi vehicles and is attached to the crossbar of the VAS 6430/1A base frame. Using an integrated laser, the 650x470 mm mirror can be aligned with the radar sensor and tilted into 3 different pitch angles via an adjustment screw. The actual software calibration is performed using the diagnostic tester. Note: Batteries are not included in the scope of delivery. 4 x 1.5V AA batteries are required. Important: Procurement is carried out exclusively through authorized Volkswagen Group distribution channels.

VAS 721 001 | 360° Umfeldkamera Kalibriermatten

Article number: ASE 721 001 00 000



Original Calibration Mats for Precise 360° Surround View Camera Calibration
360° Surround View System: Precision from a Bird's-Eye Perspective
The 360° camera system (Surround View) ensures maximum safety during maneuvering. Four cameras—located at the front, rear, and side mirrors—provide image signals that a central control unit combines in real-time into a seamless Top-View. The display shows the vehicle as if a camera were filming from a height of 20 meters.
Precision through Professional Calibration
To ensure a distortion-free perspective, all cameras must be perfectly synchronized. Using state-of-the-art diagnostic hardware and specialized calibration mats, we ensure that the system delivers geometrically correct data and that transitions between cameras are displayed seamlessly.
Manufacturer-Compliant Calibration with VAS 721 001:

- Durable Performance: UV-resistant, long-lasting, and resistant to fuels and lubricants
- High Stability: Crease-free calibration mats made of robust material for reliable and precise calibration
- User-Friendly: Clamping rails for easy and convenient rolling
- Professional Storage: Includes a cylindrical bag for proper storage

Dimensions: 8000mm x 800mm.
Important Note: When calibrating the surround view camera on a wheel alignment lift, ensure that the height difference between the vehicle's contact surface and the calibration mats is <10mm. Otherwise, correct calibration is not possible!

ADAS Calibration



VAS 6430/1A | Calibration Fixture Base Frame

Article number: ASE 423 211 01 000



VAS 6430/10 | ACC Reflective Mirror

Article number: ASE 423 220 00 000



VAS 6430/8 | Moveable Base Frame

Article number: ASE 423 218 00 000



VAS 6430/4 | Calibration Target Front Camera

Article number: ASE 423 214 00 000



VAS 6430/7 | Stationary Base Frame

Article number: ASE 423 217 00 000



VAS 6430/12 | Calibration Target LiDAR

Article number: ASE 423 222 00 000



VAS 6430/3 | ACC Reflective Mirror

Article number: ASE 423 213 00 000

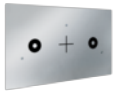

VAS 6430/11 | Calibration Target LDW

Article number: ASE 423 221 00 000

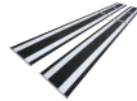

VAS 721 001 | 360° Umfeldkamera Kalibrierplatten

Article number: ASE 721 001 00 000



VAS 6430/9 | Height Spacer

Article number: ASE 423 219 00 000



VAS 6430/6 | Calibration Adapter Night Vision

Article number: ASE 423 216 01 000

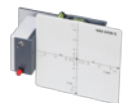

VAS 6430/2 | ACC Laser Unit

Article number: ASE 423 212 00 000

IMPORTANT NOTES

- Please notice: This list contains spare parts, too.
- Without instruction or assembly.
- Delivery ex works including packaging.

VERSION 2026.05.12 – PRICES ON REQUEST

- Starting from now all previous lists will lose their validity.
- Please read our general terms and conditions in the latest version before ordering; to be found under www.beissbarth.com.

Order number 1 693 602 008 **Print norm** BB XXX / XX.XX.2020 DE · Subject to technical and program changes, errors excepted.

Beissbarth Automotive Testing Solutions GmbH

Friedrichshafener Str. 602
82205 Gilching, Germany
sales@beissbarth.com
www.beissbarth.com

Telefon: +49-(0)89-14901-0

Telefax: +49-(0)89-14901-246

